

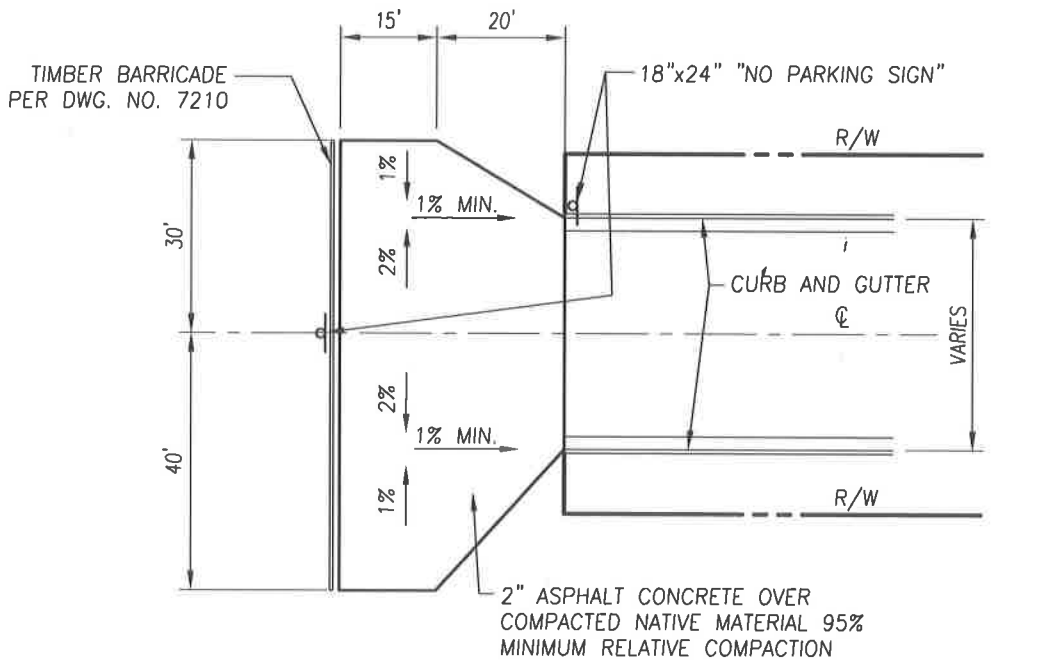

**OPTION A**



**OPTION B**

**NOTES:**

1. THESE STANDARDS ARE INTENDED FOR PUBLIC STREETS IN PHASED DEVELOPMENTS ON A TEMPORARY BASIS ONLY.
2. TURNAROUND SHALL BE REQUIRED WHEN A STUB STREET IS IN EXCESS OF 2 LOTS FROM THROUGH STREET.
3. USE OTHER THAN TEMPORARY SHALL BE AT THE DISCRETION OF THE CITY ENGINEER.

REVISIONS	DATE		<b>CITY OF TULARE</b> PUBLIC IMPROVEMENT STANDARD <b>TEMPORARY HAMMERHEAD</b> <b>TURNAROUND, PUBLIC STREET</b>	DRAWING NO.:
			Approved By: <i>Michael W. Miller</i> Date: 11/15/16      City Engineer	7111
				1 OF 1